

Investigating the solvated electron
in transient solvent structures
utilizing pump-repump-probe spectroscopy

A. Thaller, R. Laenen and A. Laubereau

Physik-Department E11
Technical University of Munich

15.03.2005

- ▶ first observation published 140 years ago
 - ▶ still of high interest:
 - ▶ important role in biochemical processes
 - ▶ tiny probe for H-bonded systems: Water, methanol, etc.
 - ▶ generation: electrochemically, radiolysis, photolysis
 - ▶ generation dynamics occurs on ps-timescale
 - ▶ first pump–probe–measurements of equilibrated e_{solv}^- by Barbara et al.
 - ▶ still open questions regarding precursing states
- spectroscopy of transient species - in methanol

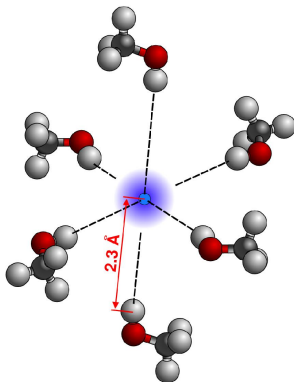

6–7 CH_3OH in first solvation shell

(Turi et al., CPL **316** (2000) 456)

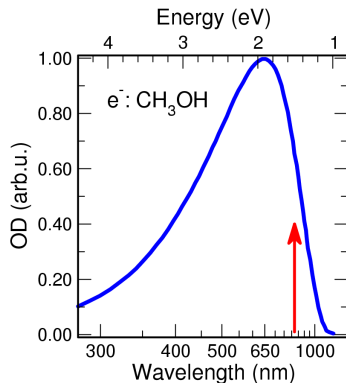

broad absorption band,
maximal abs. at 640 nm

(Jou et al. JPC **81** (1977) 909)

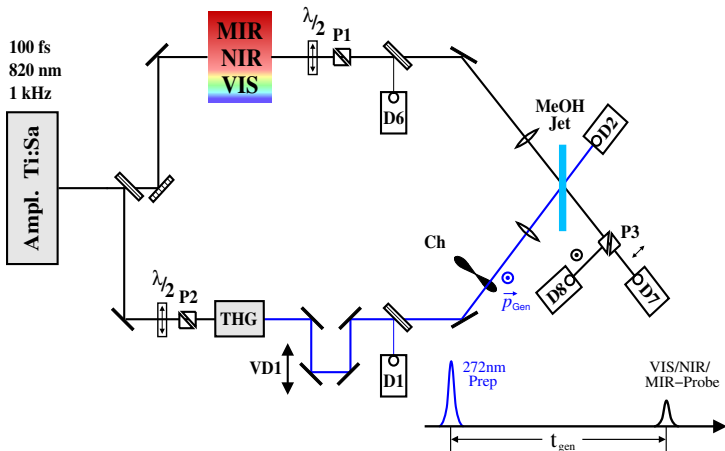

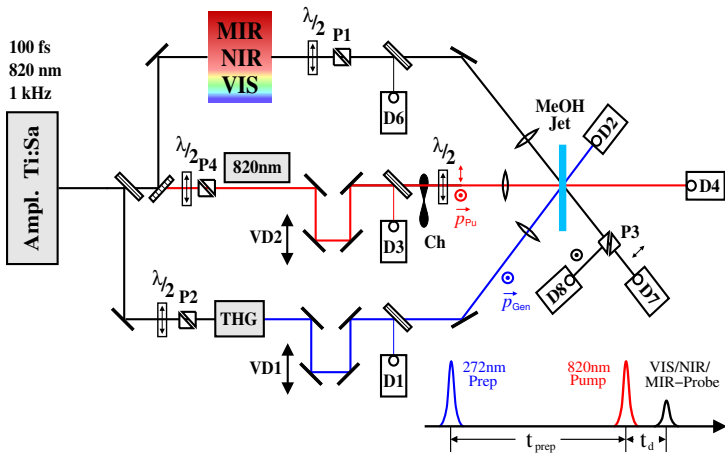

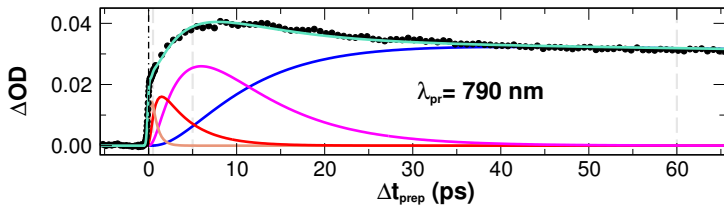

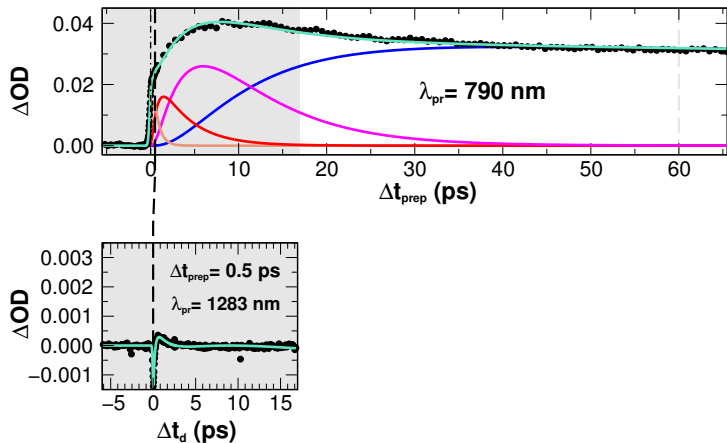

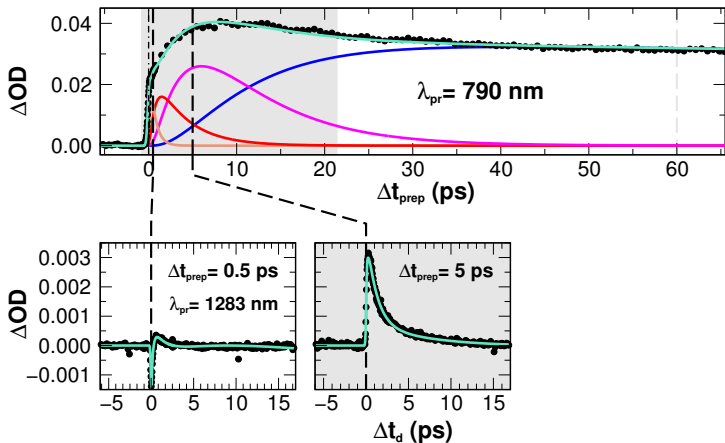

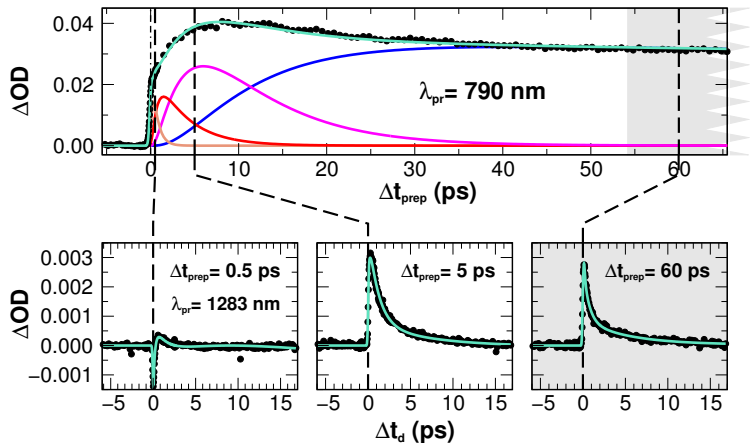

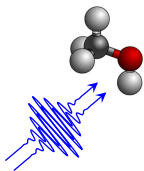

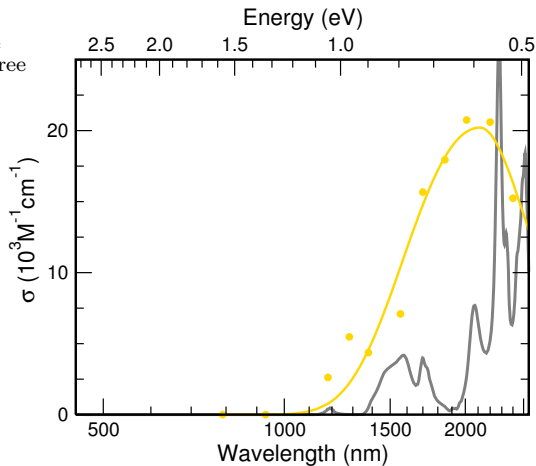
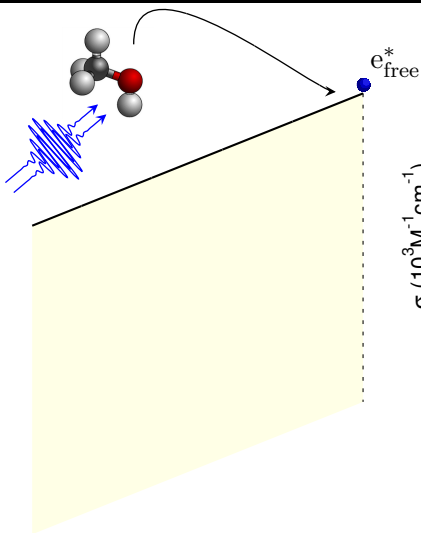

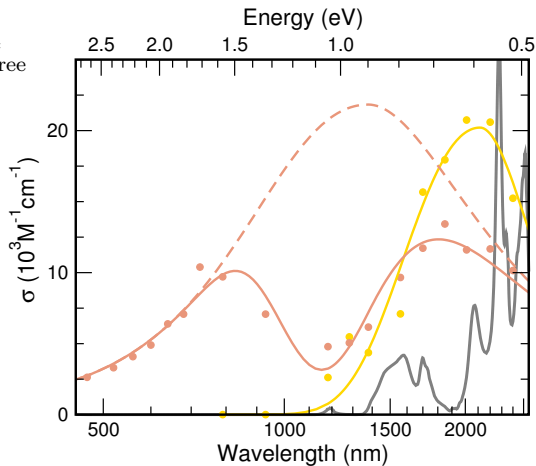
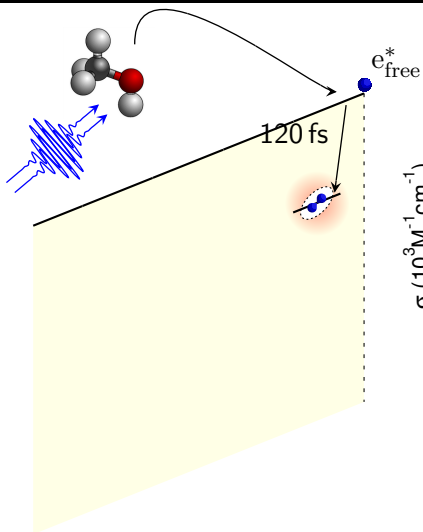

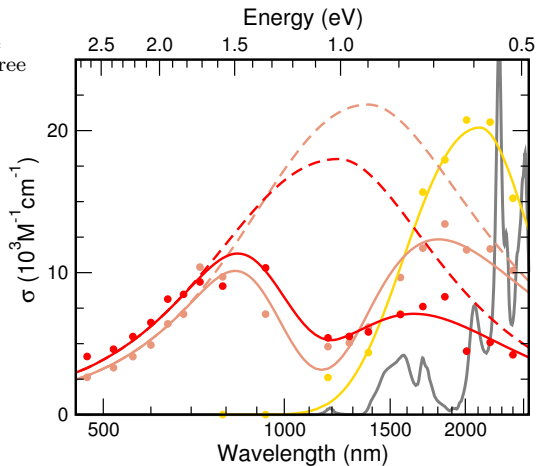
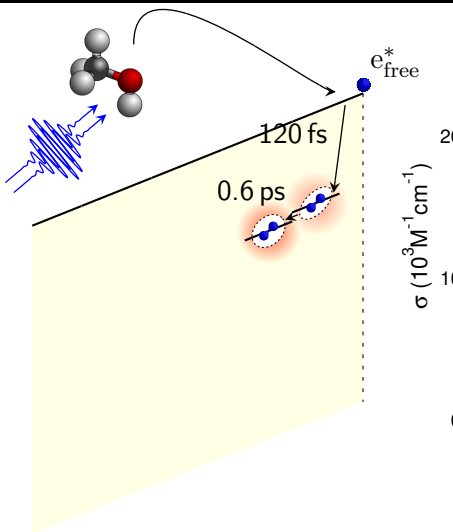

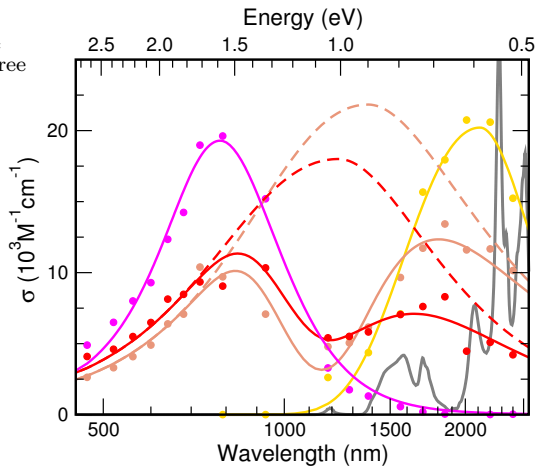
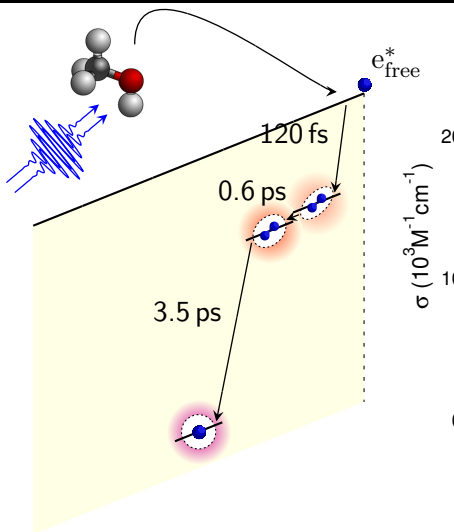

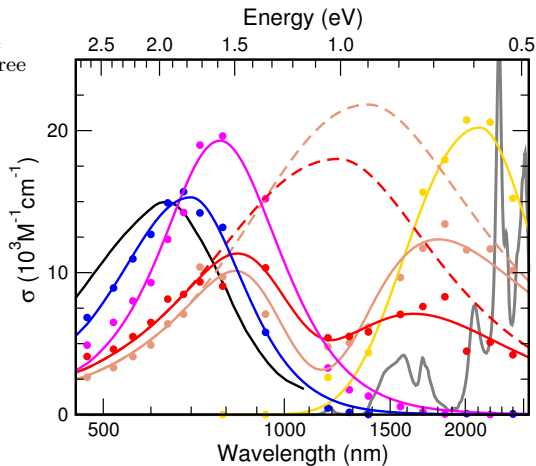
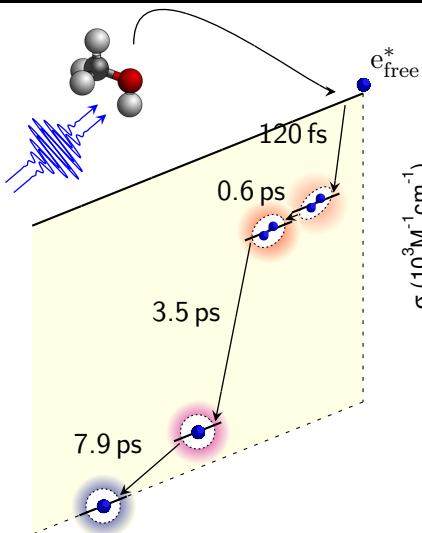

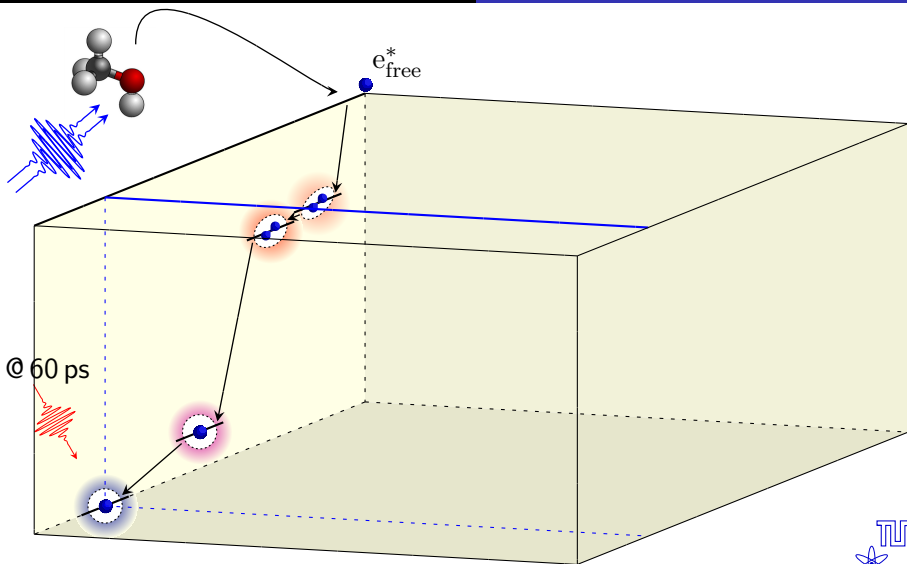

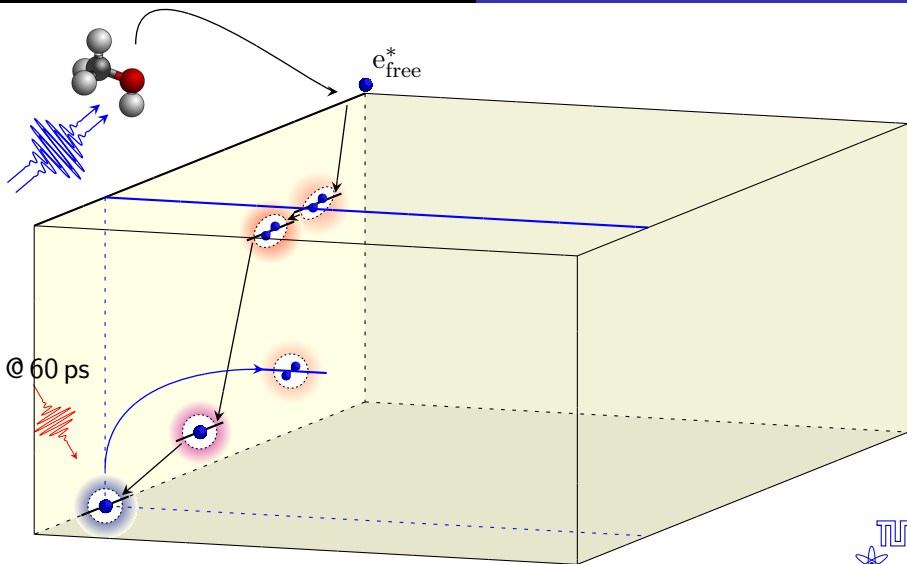

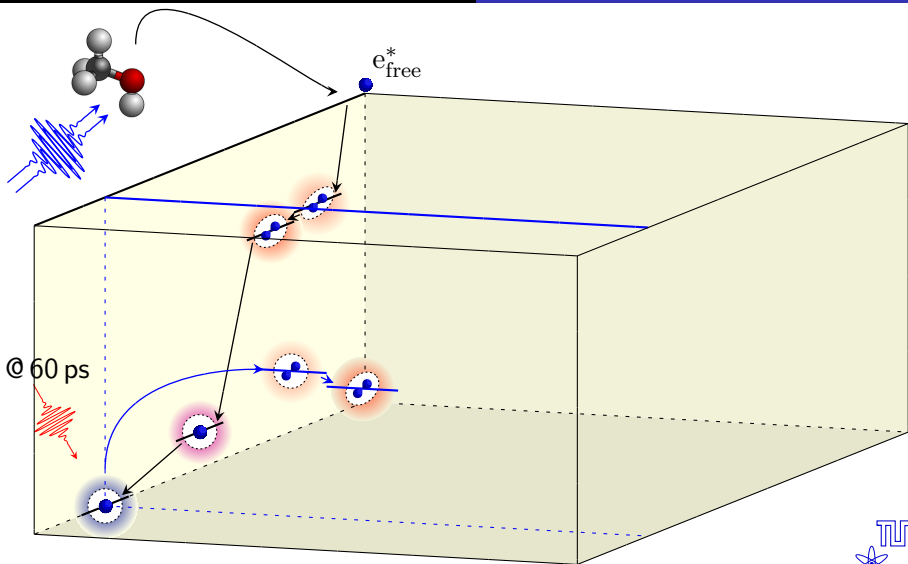

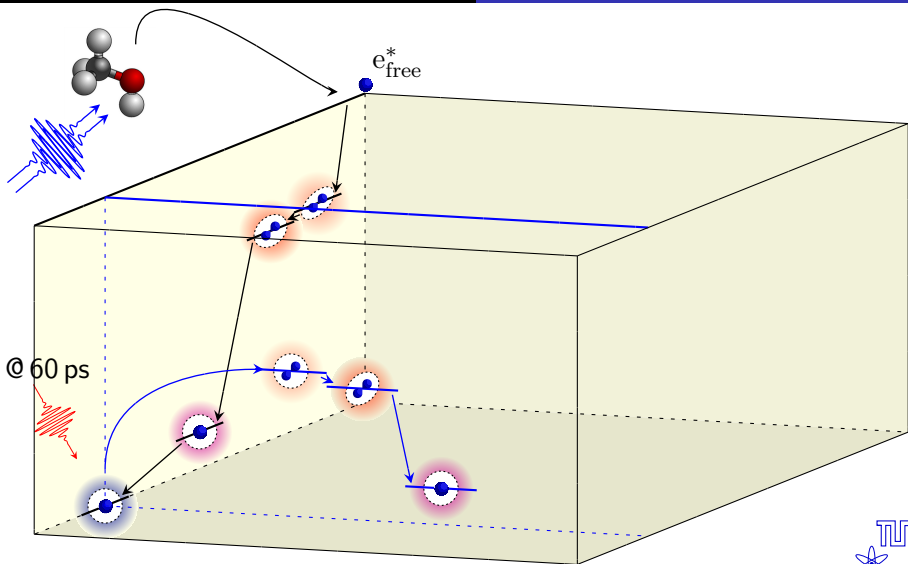

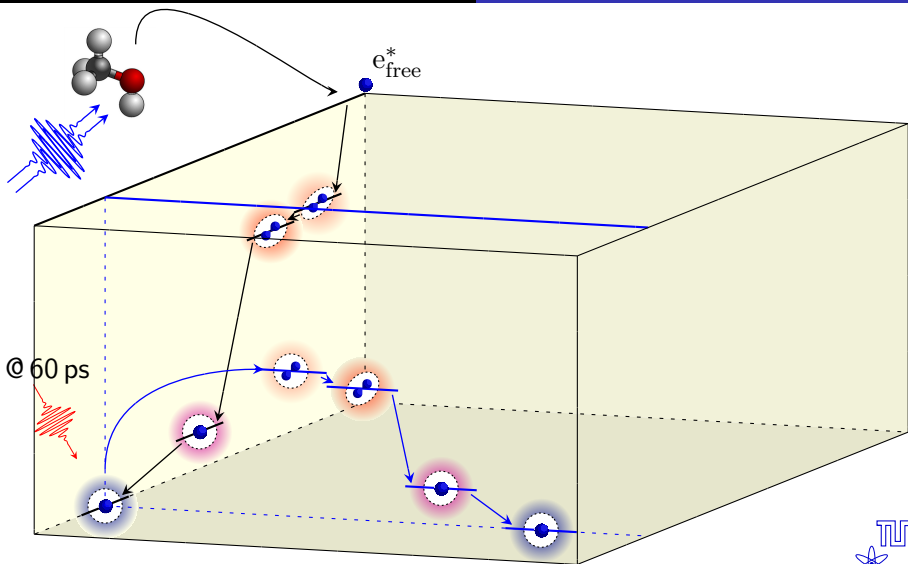

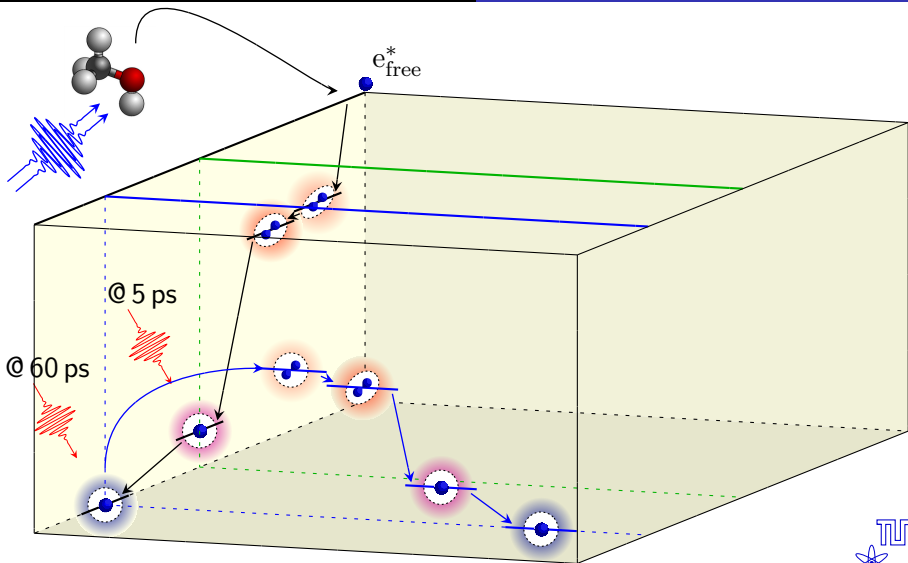

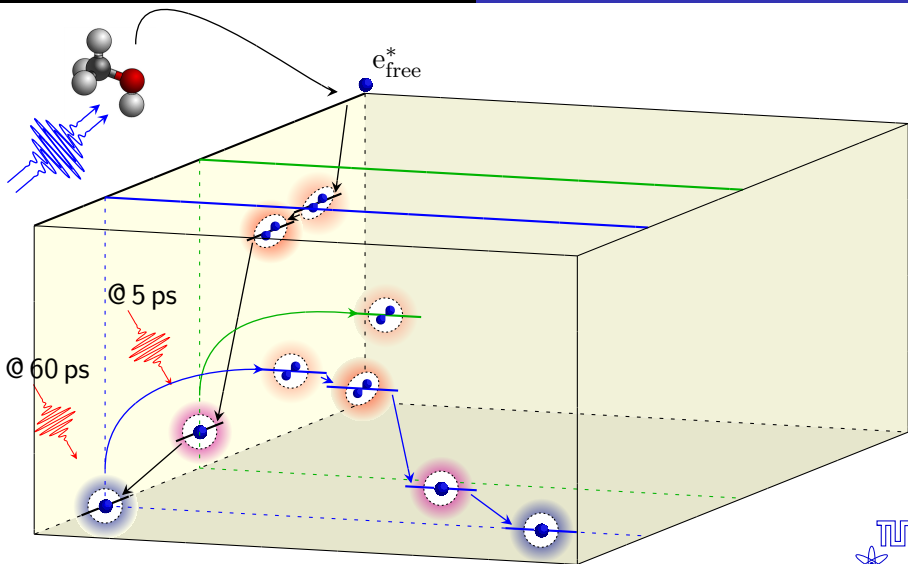

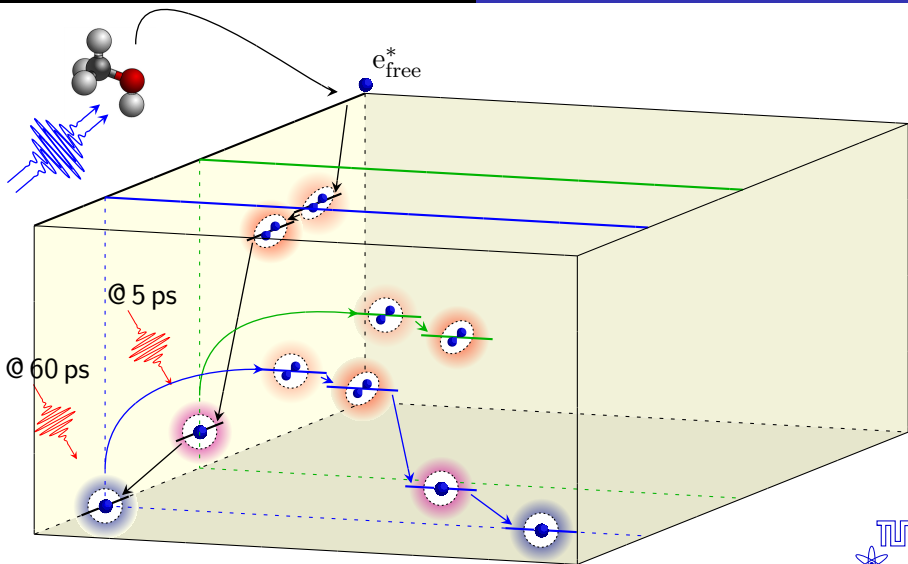

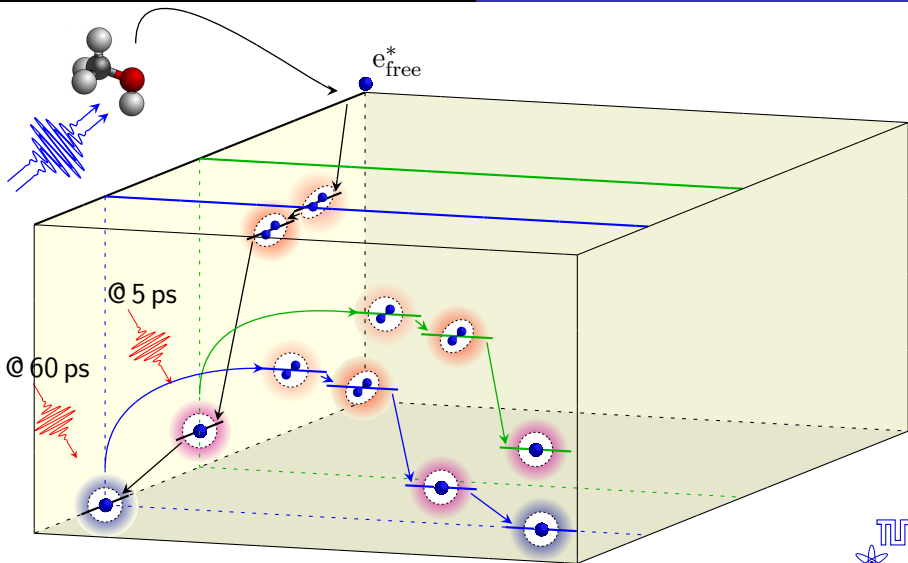

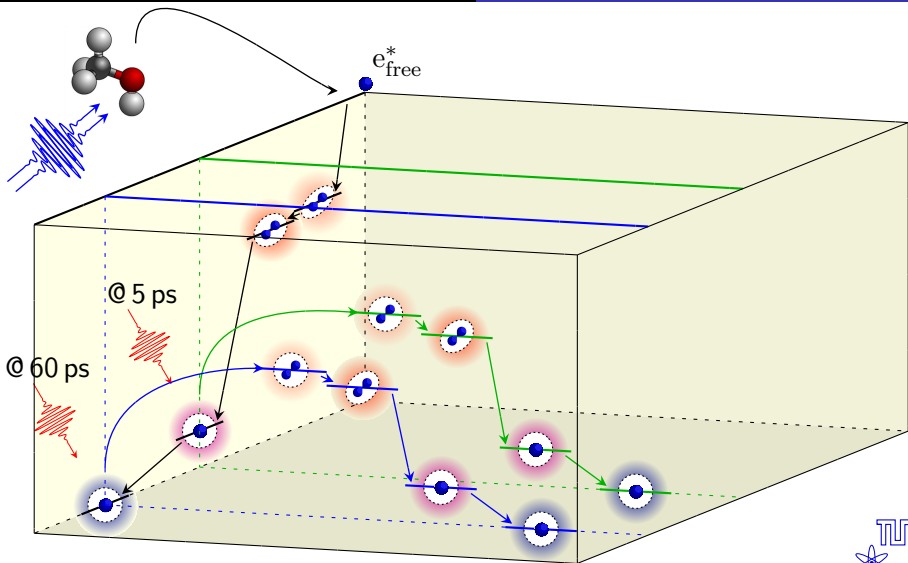

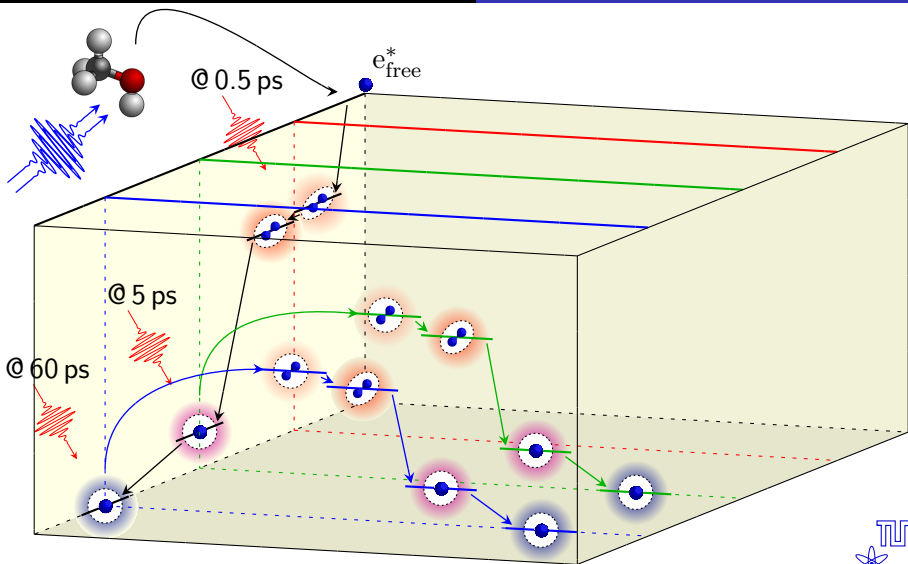

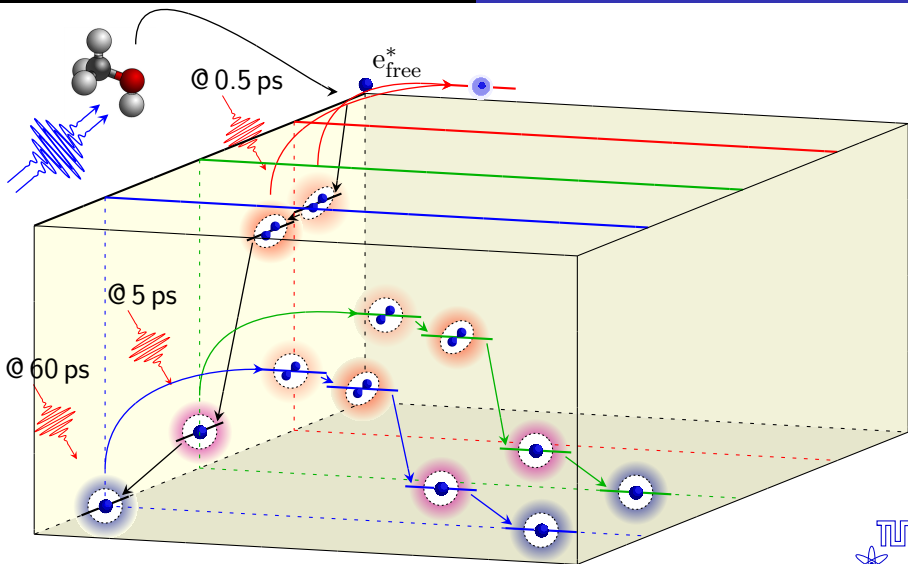

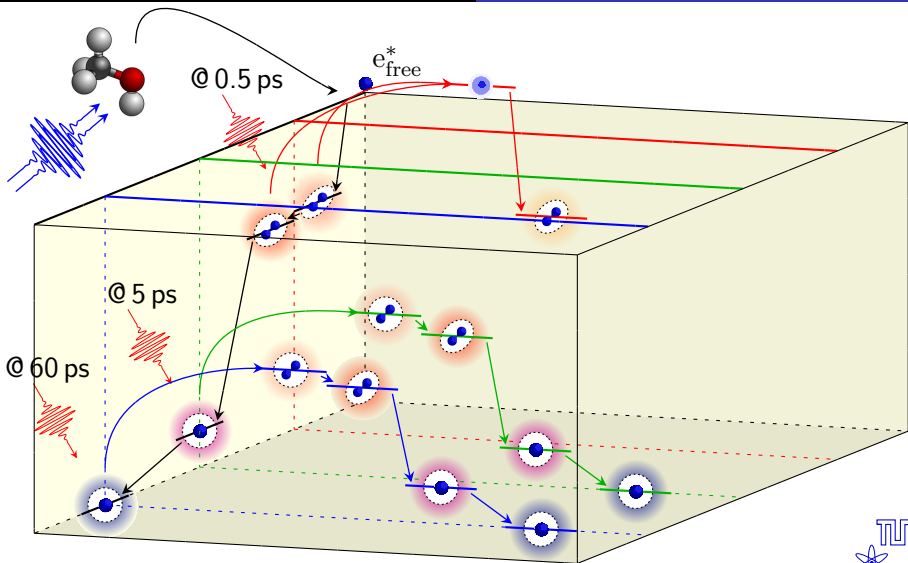

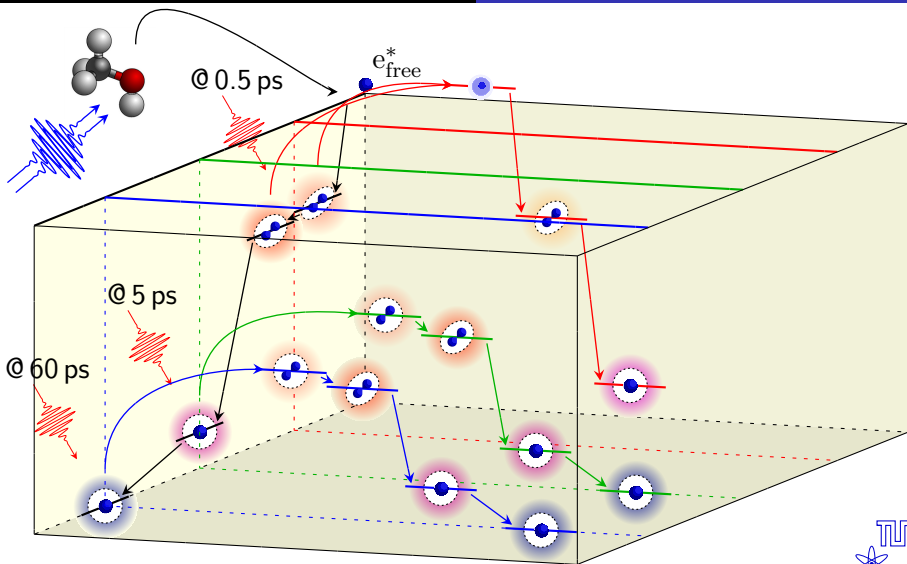

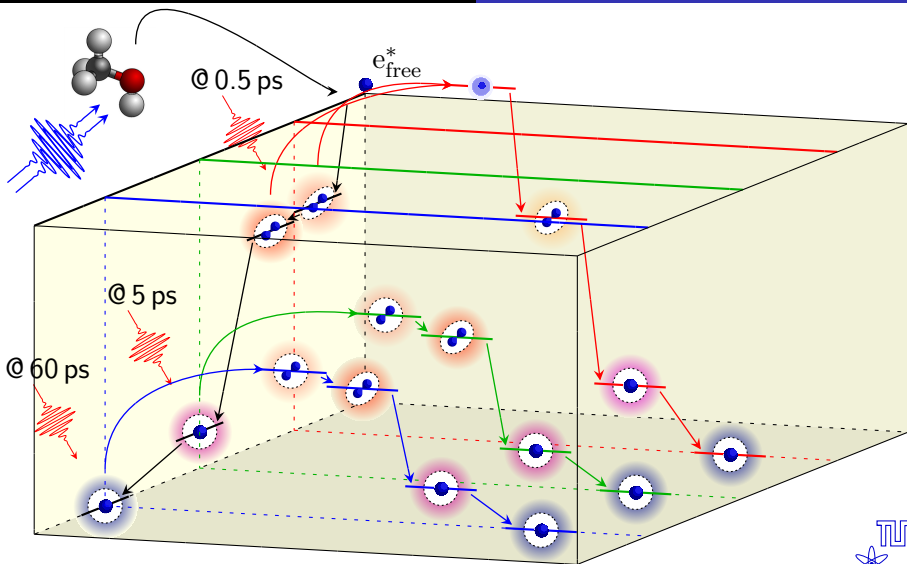

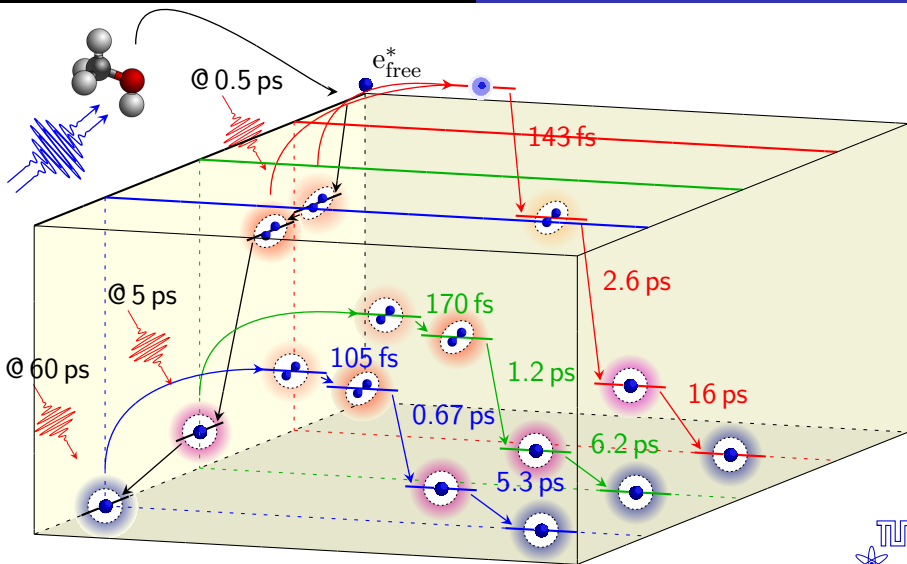

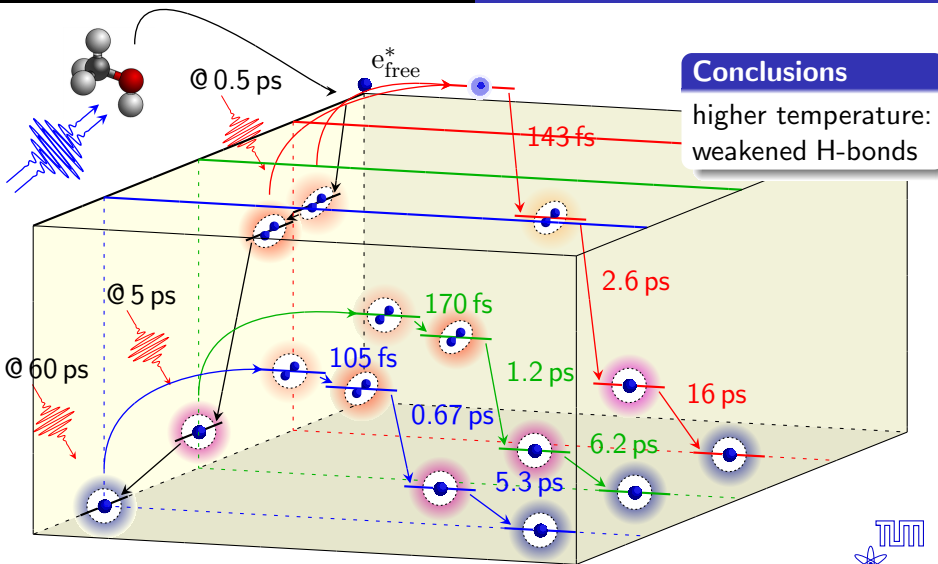

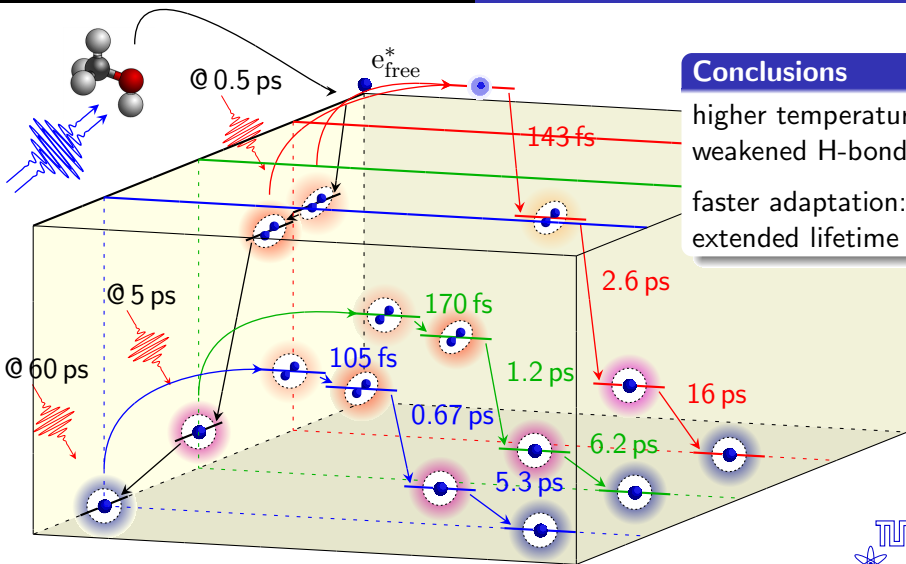

Conclusions

- higher temperature:
weakened H-bonds
- faster adaptation:
extended lifetime

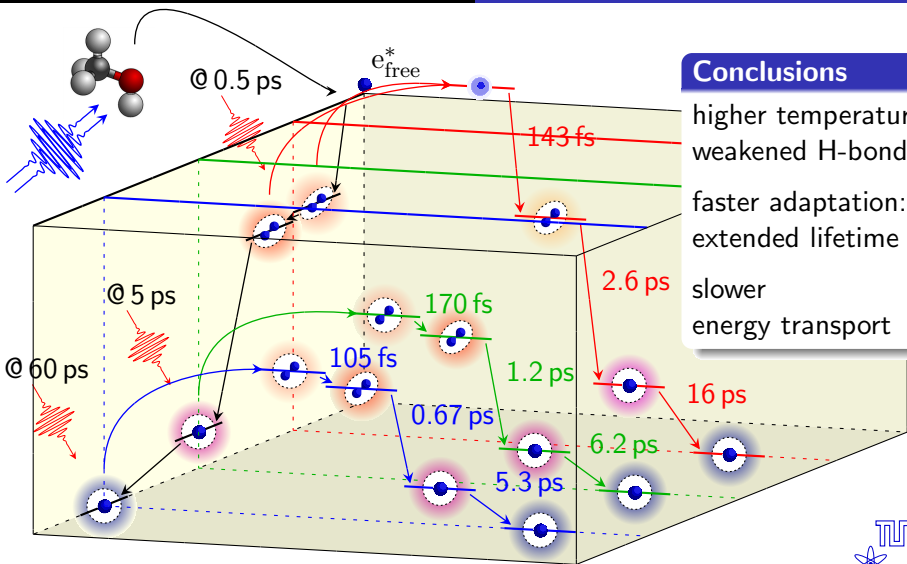

Conclusions

higher temperature:
weakened H-bonds

faster adaptation:
extended lifetime

slower
energy transport